

GIA NATURAL COLORED DIAMOND ORIGIN REPORT

November 26, 2024
 Report Type Origin Report
 GIA Report Number 5232448688
 Shape and Cutting Style Oval Modified Brilliant
 Measurements 18.04 x 12.07 x 7.71 mm

Carat Weight 13.12 carat
 Color Grade Fancy Brownish Yellow
 Color Origin Natural
 Color Distribution Even
 Clarity Grade VVS2
 Proportions:

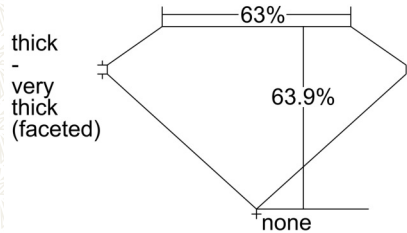

Profile not to actual proportions

Polish Excellent
 Symmetry Excellent
 Fluorescence Faint
 Inscription(s): GIA 5232448688

ADDITIONAL INFORMATION

GIA COLORED DIAMOND SCALE

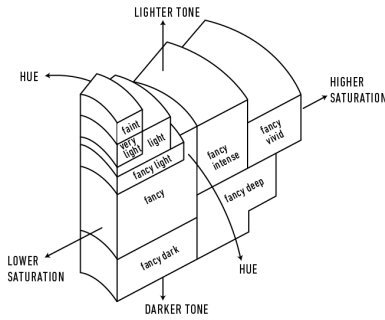

Illustration of GIA fancy color grade interrelationships

GIA CLARITY SCALE

FLAWLESS
INTERNALLY FLAWLESS
VVS ₁
VVS ₂
VS ₁
VS ₂
SI ₁
SI ₂
I ₁
I ₂
I ₃

VERY VERY SLIGHTLY INCLUDED
 VERY SLIGHTLY INCLUDED
 SLIGHTLY INCLUDED
 INCLUDED

CLARITY CHARACTERISTICS

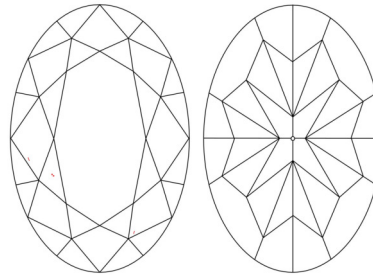

KEY TO SYMBOLS*

- Needle
- Pinpoint

* Red symbols denote internal characteristics (inclusions). Green or black symbols denote external characteristics (blemishes). Diagram is an approximate representation of the diamond, and symbols shown indicate type, position, and approximate size of clarity characteristics. All clarity characteristics may not be shown. Details of finish are not shown.

ORIGIN RESULTS

Country of Origin ◊ South Africa



◊ Origin is determined via documentary evidence from the miner. Scientific matching of rough to polished performed by GIA.

reportcheck.gia.edu

The results documented in this report refer only to the diamond described, and were obtained using the techniques and equipment available to GIA at the time of examination. This report is not a guarantee or valuation. For additional information and important limitations and disclaimers, please see GIA.edu/terms or call +1 800 421 7250 or +1 760 603 4500. ©2023 Gemological Institute of America, Inc.

